

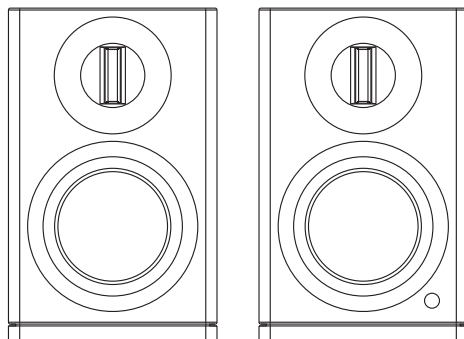

# HiVi-Swans Dazzle Prime

## Active Speaker Manual



**For Multi-language Instructions:**

Please scan the QR code. You will be guided to select and view/download the manual in your preferred language.

## Warning

---

### IMPORTANT SAFETY INSTRUCTIONS WARNING

To reduce the risk of fire or electric shock, do not expose this apparatus to rain or moisture.



 The lightning flash is intended to alert you to the presence of uninsulated "dangerous voltage" within the product's enclosure that may be of sufficient magnitude to constitute an electric shock to persons.

 The exclamation point is intended to alert you to the presence of important operating and maintenance (servicing) instructions in the literature accompanying the appliance.

Before connecting or using this apparatus, do read carefully all safety warning and instructions. Please keep this instruction for future reference.

This device should be installed or set up in a position that ventilation can be assured. Never put the device in a place that air flow over the ventilation openings might be hindered, such as in a bookshelf or a drawer.

This product should be operated only from the type of power source indicated on the back panel of the device. The power cord of this product should be restored in a place that is less possibly be walked on or get pierced, especially its plug, convenience receptacles and the point where power cord exit from the apparatus.

Before cleaning this product, make sure the plug is disconnected from the outlet. Proceed with the cleaning in the way that this instruction recommends only.

When this product is not in use for a long time, make sure to unplug the power cord from the AC outlet.

If below problem happens, send this product to a qualified service personnel for repairing.

- A. Power cord or power plug is damaged.
- B. Objects have fallen or liquid has been spilled into this product.
- C. This product is exposed to rain or other liquid.
- D. This product functions abnormally or very poorly.
- E. This product has been dropped or has a damaged enclosure.

Never to attempt to repair this product by yourself. Refer all servicing to a qualified servicing personnel.

### CAUTION

To reduce the risk of electric shock, the power plug must be completely inserted into an AC outlet.

This product does not contain any parts or components that can be repaired by users themselves. Do not open the enclosure, otherwise it may result in an electric shock. Refer all servicing to a qualified servicing personnel.

When you unplug this product from AC outlet, do hold the power plug and pull.

Do not pull the power cord. Do not overload AC outlets or the extension cord, as this can lead to risk of fire or electric shock.

## Warning

---

When repairing or replacement of parts is required, make sure the service technician has used the parts/components specified by the manufacturer or parts/components that have the same characteristics as the original parts/components. Unauthorized substitutions may result in risk of fire, electric shock or other hazards.

### POWER SOURCE

Before connecting this product with AC outlet, do check and make sure the electric supply voltage is as same as it is marked on the rear panel of this product.

**WARNING:** It's very dangerous to insert a power plug that has bare wire into an AC outlet.

### DECLARATION

This product does not contain any parts or components that can be repaired by users themselves. If there is any malfunction, refer to this instruction or ask for repair by a qualified service technician. Do not try to repair by yourself, otherwise the manufacturer will not be responsible for any consequences resulted there from.

## FCC Warning

---

This device complies with Part 15 of the FCC Rules. Operation is subject to the following two conditions:

(1) This device may not cause harmful interference, and (2) this device must accept any interference received, including interference that may cause undesired operation.

### NOTE 1:

This equipment has been tested and found to comply with the limits for a Class B digital device, pursuant to Part 15 of the FCC Rules. These limits are designed to provide reasonable protection against harmful interference in a residential installation. This equipment generates uses and can radiate radio frequency energy and, if not installed and used in accordance with the instructions, may cause harmful interference to radio communications. However, there is no guarantee that interference will not occur in a particular installation. If this equipment does cause harmful interference to radio or television reception, which can be determined by turning the equipment off and on, the user is encouraged to try to correct the interference by one or more of the following measures:

- Reorient or relocate the receiving antenna.
- Increase the separation between the equipment and receiver.
- Connect the equipment into an outlet on a circuit different from that to which the receiver is connected.
- Consult the dealer or an experienced radio/TV technician for help.

### NOTE 2:

Any changes or modifications to this unit not expressly approved by the party responsible for compliance could void the user's authority to operate the equipment.

This equipment complies with the FCC RF radiation exposure limits set forth for an uncontrolled environment. This equipment should be installed and operated with a minimum distance of 20 cm between the radiator and any part of your body.

# Unpacking & Schematic Diagram

Please make sure all the following components are in the box.

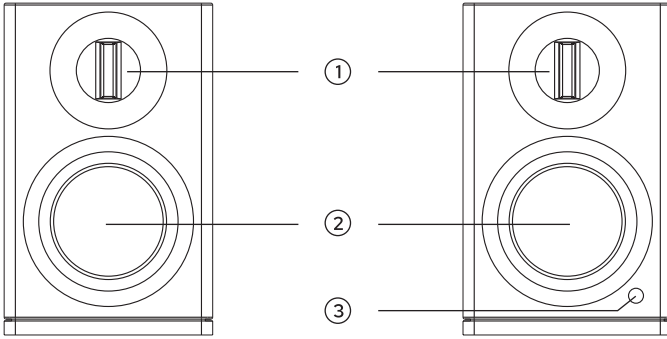

Slave speaker

Master speaker

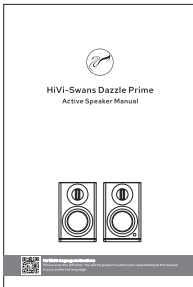

Manual

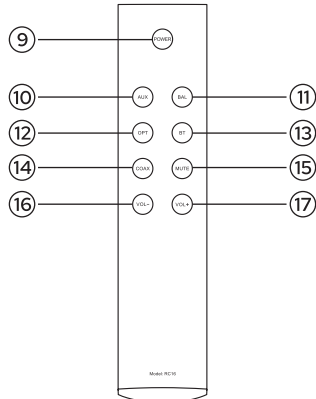

# Unpacking & Schematic Diagram

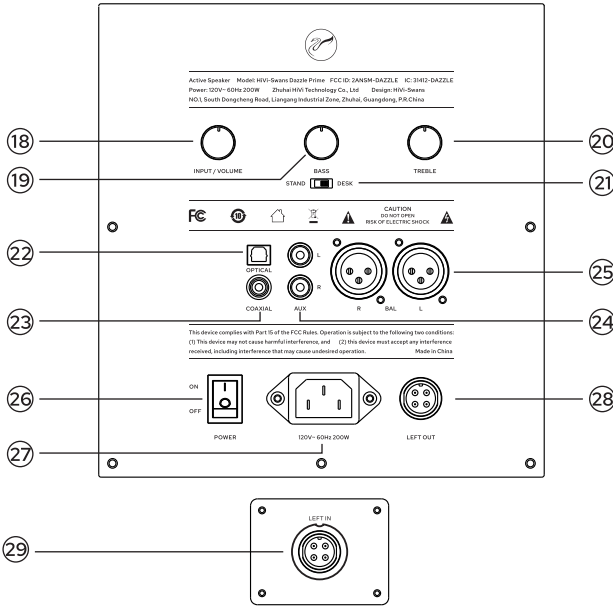

1. Isodynamic Ribbon Tweeter  
3. Receiver / Indicator Light

2. Woofer

4. Power Cable  
6. Optical Connection Cable  
8. Speaker Connection Cable

5. Dual RCA to 3.5 mm Audio Cable  
7. Coaxial Cable

9. Power  
11. Balance Input (Indicator Light Yellow)  
13. Bluetooth Input (Indicator Light Blue)  
15. Mute (Indicator Light Red)  
17. Volume Up

10. AUX Input (Indicator Light Light Blue)  
12. Optical Input (Indicator Light White)  
14. Coaxial Input (Indicator Light Purple)  
16. Volume Down

18. Input/Volume Control: Turn clockwise to increase the volume.  
Press repeatedly to cycle through the available modes  
(AUX, Bluetooth...)

19. Bass Control:  $\pm 3$  dB; clockwise + 3 dB, counterclockwise - 3 dB  
20. Treble Control:  $\pm 3$  dB; clockwise + 3 dB, counterclockwise - 3 dB  
21. STAND / DESK Mode  
22. Optical Interface  
23. Coaxial Interface  
24. AUX Interface  
25. Balance Interface  
26. Power Switch  
27. Power Socket  
28. Left Speaker Out  
29. Left Speaker In

# Speaker Connection

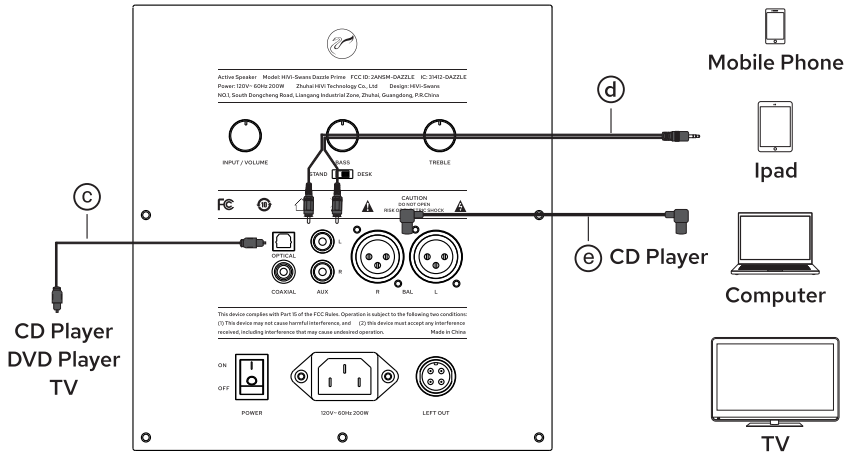
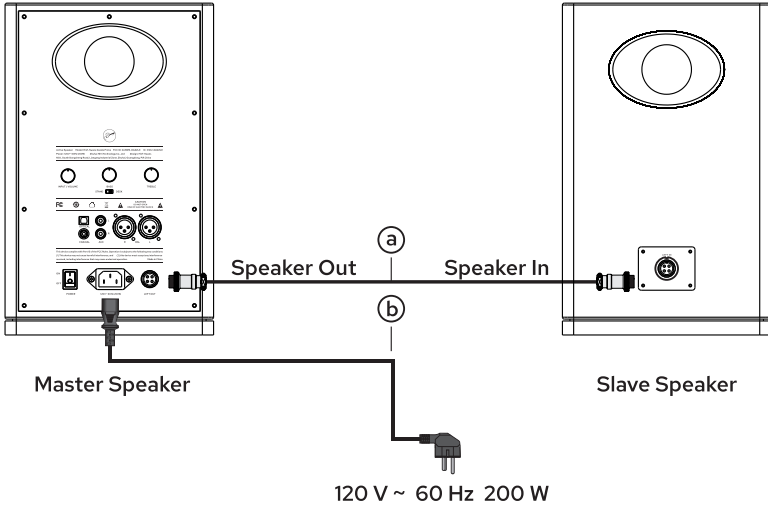

- a) Connection of master speaker and slave speaker.
- b) Connect master speaker to the power source.
- c) Optical connection with CD Player / DVD Player / TV.
- d) AUX connection with computers, TV or tablets etc.
- e) Balance connection with CD Player.

# Bluetooth Connection

Select Bluetooth mode via the remote control or press Input / Volume control on the back panel. Indicator light should flash blue. Choose Dazzle Prime on your phone. Steady blue light indicates successful Bluetooth connection.

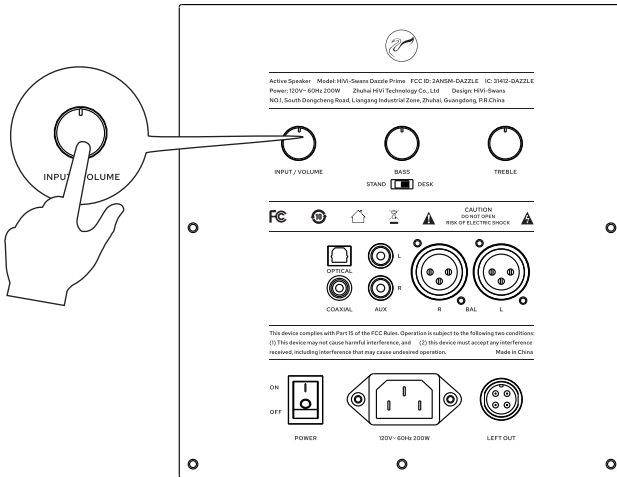
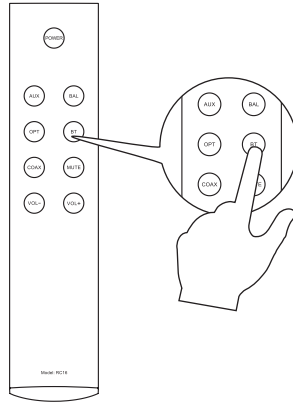

# Speaker Placement

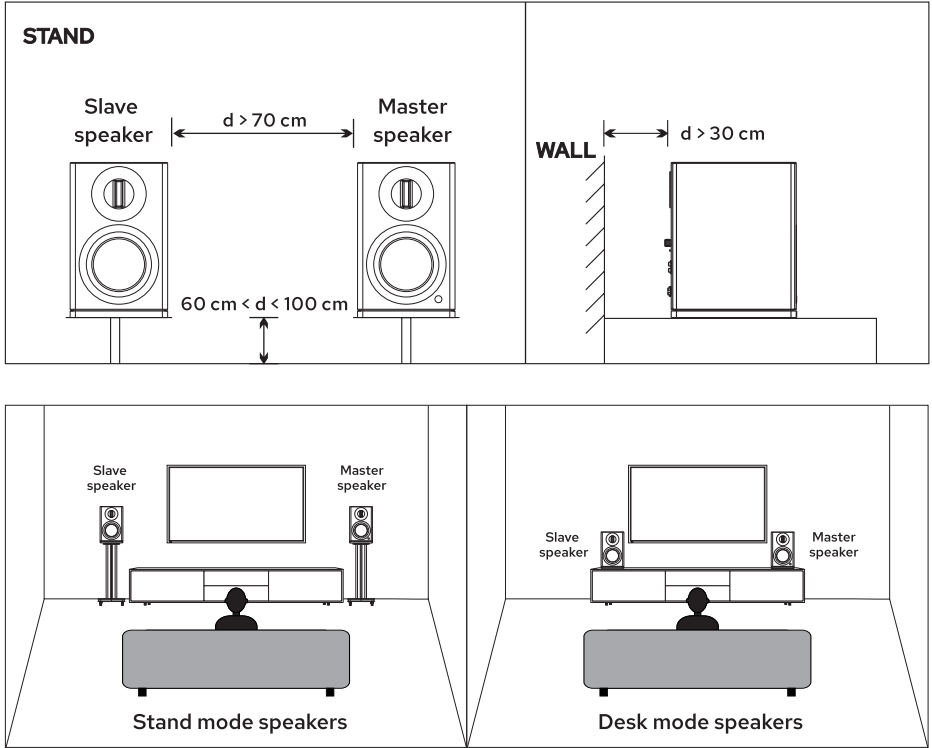

When the speaker is switched to an appropriate mode, its preset DSP data will be activated to help get a relatively flat response from the speaker. And the sound quality will be substantially improved.

About the placement of stand mode speakers: When you need to put the speaker on a dedicated speaker stand, you should switch the selector switch of speaker's back panel to STAND mode.

About the placement of desk mode speakers: When you need to put the speaker on the computer desk or TV bench, you should switch the selector switch of speaker's back panel to DESK mode.

## Specifications

---

Series	Active Speaker
Model	HiVi-Swans Dazzle Prime
System Type	2-way 4th-order vented speaker system
Drivers Configuration	6.5" woofer ; isodynamic ribbon tweeter
Frequency Range	38 Hz - 40 kHz
Audio Input	Bluetooth / Optical / Coaxial / Balance / Line
Amplifier Output:	Tweeter 30 W x 2 RMS, Woofer 120 W x 2 RMS Total 300 W RMS
Active DSP crossover frequency	3.0 kHz
Bass tuning	$\pm 3$ dB
Treble tuning	$\pm 3$ dB
Separation	> 87 dB
Signal-to-Noise	> 102 dB (A weighted)
Dimensions (W x D x H)	223 x 300 x 359 mm
Net Weight	Master speaker 10.3 kg, Slave speaker 9.2 kg

## Burn-in

---

Burn-in is the procedure which can enable the speakers to perform best acoustically. A period ranging from 48 - 100 hours of usage is recommended before both the amplifier and speaker drivers behave optimally.

Alternatively, you can listen 2 or 3 hours every day at a medium volume, and the speakers will be burned-in one month or so.

## Maintenance

---



a)

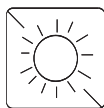

b)

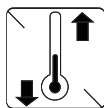

c)

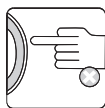

d)



e)

- a) Avoid magnetic disturbance.
- b) Do not place under the sunshine for a long time.
- c) Do not place in high temperature or moist environment for a long time.
- d) Do not touch the drivers with your hands.
- e) Avoid corrosive liquids and gases.

## Trouble Shooting

---

1. If there is problem with sound quality.

- a) Check if all the drivers are working.
- b) Check that audio cables are firmly connected at both ends.

2. If there is no sound from either of the speakers:

- a) Check if the device is on and if a source is playing.
- b) Check if the volume is not on minimum.
- c) Check if there is broken or short circuit with the cable connecting speakers and audio source.

3. If there is no sound coming from one of the speakers:

- a) Check the setting of the audio source.
- b) Check that all the audio cable are firmly connected at both ends.

## Notice

---

 The crossed-out wheeled bin symbol on this product indicates that electrical and electronic products should not be disposed of as unsorted municipal waste. Please dispose of waste equipment at designated collection points for separate collection and recycling.

## IC Warning

---

This device contains licence-exempt transmitter(s) that comply with Innovation, Science and Economic Development Canada's licence-exempt RSS(s). Operation is subject to the following two conditions:

- (1) This device may not cause interference.
- (2) This device must accept any interference, including interference that may cause undesired operation of the device.

L'émetteur/récepteur exempt de licence contenu dans le présent appareil est conforme aux CNR d'Innovation, Sciences et Développement économique Canada applicables aux appareils radio exempts de licence. L'exploitation est autorisée aux deux conditions suivantes:

1. 'appareil ne doit pas produire de brouillage;
2. 'appareil doit accepter tout brouillage radioélectrique subi, même si le brouillage est susceptible d'en compromettre le fonctionnement.

### RF exposure statement

This equipment complies with the ISED radiation exposure limits set forth for an uncontrolled environment. This transmitter must not be co-located or operating in conjunction with any other antenna or transmitter.

Cet équipement est conforme aux limites d'exposition aux rayonnements de l'ISED établies pour un environnement non contrôlé. Cet émetteur ne doit pas être colocalisé ou fonctionner en conjonction avec une autre antenne ou un autre émetteur.

www.swanspeakers.com    <https://www.facebook.com/SwansSpeakers/>    Ver 2  
Zhuhai HiVi Technology Co., Ltd.    E-mail: sales@swanspeaker.com  
No.1, South Dongcheng Road, Liangang Industrial Zone, Zhuhai, Guangdong, P.R.China

---

Due to the reasons in the change of design or others, product information contained here may not be in conformity with product itself. We reserve the right of no prior notice before change.